

NPN

New Product News



TBTA-TR Line Expansion and Improvements





KEY POINT

TaeguTec's TBTA-TR line diameter range expanded and updated for improved performance.

The TBTA-TR line, a three-corner insert type drill including chip splitter, is in the spotlight for its excellent performance in the deep hole machining market. To continue meeting this market demand, TaeguTec has expanded the TBTA-TR product drill range from 16.00-40.00 mm to 14.00-40.00 mm. In addition, various improvements and updates have been introduced to the entire TBTA-TR line for better stability and enhanced machining performance.

TBTA-TR single tube line diameter expansion

TBTA-TR Line		Tool diameter range (mm)	
		Existing	Expansion
	TBTA-TR...SE4 Outer four start thread	16.00-40.00	➔ 14.00-40.00
	TBTA-TR...SI Inner single start thread	16.00-40.00	➔ 14.50-40.00

TBTA-TR Improvements



- New pocket design prevents guide pad breakage when retracting from the drill hole
- Higher hardness factor for longer tool life
- Improved coolant flow for good chip evacuation and hole accuracy
- Updated screw design and material type for higher rigidity insert clamping

Updated spare parts

- Various components in the Ø16.00-28.00 mm range have been updated for improved performance.

Components	Diameter range	Existing	Updated
Insert screw	16.00-20.00	CSTB2.5S	SR 14-560/S
	20.01-21.99	CSTB3S	SR 34-506
	25.01-28.00	CSTB4S	SR 14-506
Guide pad	16.00-18.00	PAD-GP06-20-075-DC-SB	PAD-GP05-18-075-DC-SB
		PAD-GP06-20-075-DC-SC	PAD-GP05-18-075-DC-SC
Guide pad screw	16.00-28.00	CSTB2.2S	SR 34-508

※Note: The updated guide pads are not compatible with existing holders due to their size.

Updated tools

- Below tools have been updated according to the guide pads size modification. (not compatible with existing tools)
- For identification purposes, the updated tools include an 'A' added to the end of their designation.

Diameter range	Tool	Existing	Updated
16.00-18.00	Outer thread	TBTA- TRxx.xxSE4-14	TBTA- TRxx.xxSE4-14A
		TBTA- TRxx.xxSE4-15	TBTA- TRxx.xxSE4-15A
		TBTA- TRxx.xxSE4-16	TBTA- TRxx.xxSE4-16A
	Inner thread	TBTA- TRxx.xxSI1-13A	TBTA- TRxx.xxSI1-13AA
		TBTA- TRxx.xxSI1-13B	TBTA- TRxx.xxSI1-13BA
		TBTA- TRxx.xxSI1-14A	TBTA- TRxx.xxSI1-14AA
		TBTA- TRxx.xxSI1-14B	TBTA- TRxx.xxSI1-14BA

TBTA-TR...SE4



Single tube system

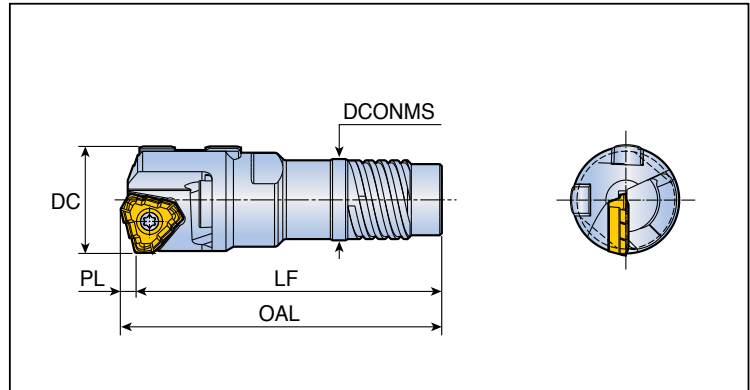

- Outer four start thread

Designation	DC	Dimension (mm)				Tube	
		LF	OAL	DCONMS	PL	Part	Diameter (mm)
TBTA- TRxx.xxSE4-12 new	14.00-14.60	57.0	59.0	10.6	2.0	BTSI 012	12
TRxx.xxSE4-13 new	14.61-15.59	57.0	59.0	11.6	2.0	BTSI 013	13
TRxx.xxSE4-14 new	15.60-15.99	57.0	59.0	12.6	2.0	BTSI 014	14
TRxx.xxSE4-14A	16.00-16.70	55.0	57.2	12.6	2.2	BTSI 014	14
TRxx.xxSE4-15A	16.71-17.70	55.0	57.2	13.6	2.2	BTSI 015	15
TRxx.xxSE4-16A	17.71-18.00	56.0	59.0	14.5	3.0	BTSI 016	16
TRxx.xxSE4-16	18.01-18.90	56.0	59.0	14.5	3.0	BTSI 016	16
TRxx.xxSE4-17	18.91-20.00	56.0	59.0	15.5	3.0	BTSI 017	17
TRxx.xxSE4-18	20.01-21.80	60.0	63.2	16.0	3.2	BTSI 018	18
TRxx.xxSE4-20	21.81-21.99	63.5	66.7	18.0	3.2	BTSI 020	20
TRxx.xxSE4-20	22.00-24.10	65.5	68.9	18.0	3.4	BTSI 020	20
TRxx.xxSE4-22	24.11-26.40	65.5	69.1	19.5	3.6	BTSI 022	22
TRxx.xxSE4-24	26.41-28.00	65.6	69.1	21.0	3.6	BTSI 024	24
TRxx.xxSE4-24	28.01-28.70	70.0	74.6	21.0	4.6	BTSI 024	24
TRxx.xxSE4-26	28.71-29.99	75.0	79.6	23.5	4.6	BTSI 026	26
TRxx.xxSE4-26	30.00-31.00	75.0	79.6	23.5	4.6	BTSI 026	26
TRxx.xxSE4-28	31.01-32.00	75.0	79.6	25.5	4.6	BTSI 028	28
TRxx.xxSE4-28	32.01-33.30	74.5	79.9	25.5	5.4	BTSI 028	28
TRxx.xxSE4-30	33.31-36.20	79.5	84.9	28.0	5.4	BTSI 030	30
TRxx.xxSE4-33	36.21-39.00	89.5	94.9	30.0	5.4	BTSI 033	33
TRxx.xxSE4-33	39.01-39.60	89.5	94.9	30.0	5.4	BTSI 033	33
TRxx.xxSE4-36	39.61-40.00	94.5	99.9	33.0	5.4	BTSI 036	36

► Insert and guide pad are sold separately from drill body

TBTA-TR...SI



Single tube system

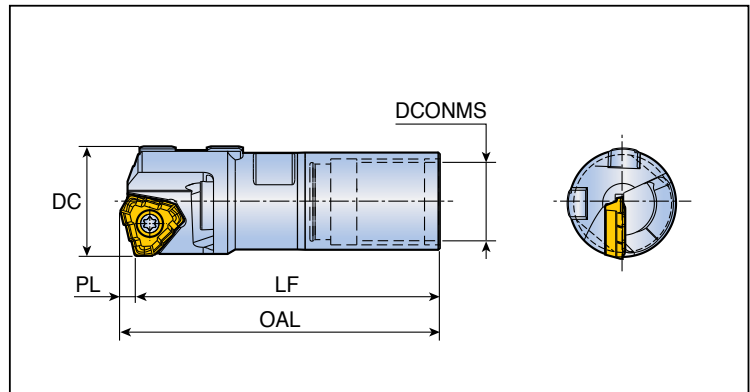

- Inner single start thread

Designation	DC	Dimension (mm)				Tube	
		LF	OAL	DCONMS	PL	Part	Diameter (mm)
TBTA- TRxx.xxSI-12A <small>(new)</small>	14.50-15.00	54.5	56.4	11.5	1.9	BTSE 012A	12
TRxx.xxSI-12B <small>(new)</small>	15.01-15.50	54.5	56.4	11.8	1.9	BTSE 012B	12
TRxx.xxSI-13A <small>(new)</small>	15.51-15.99	54.5	56.4	12.4	1.9	BTSE 013A	13
TR16.00SI-13AA	16.00	53.5	55.7	10.8	2.2	BTSE 013A	13
TRxx.xxSI-13BA	16.01-16.50	53.5	55.7	11.1	2.2	BTSE 013B	13
TRxx.xxSI-14AA	16.51-17.25	53.5	55.7	11.8	2.2	BTSE 014A	14
TRxx.xxSI-14BA	17.26-18.00	53.5	55.7	12.1	2.2	BTSE 014B	14
TRxx.xxSI-15	18.01-19.00	53.5	56.5	12.8	3.0	BTSE 015	15
TRxx.xxSI-16.5	19.01-19.99	53.5	56.7	13.8	3.2	BTSE 016.5	16.5
TRxx.xxSI-18	20.00-21.99	58.0	61.2	14.5	3.2	BTSE 018	18
TRxx.xxSI-20	22.00-24.99	60.0	63.4	16.0	3.4	BTSE 020	20
TRxx.xxSI-22	25.00	60.0	63.5	17.0	3.5	BTSE 022	22
TRxx.xxSI-22	25.01-26.99	65.0	68.5	17.0	3.5	BTSE 022	22
TRxx.xxSI-24	27.00-28.00	65.0	68.5	19.0	3.5	BTSE 024	24
TRxx.xxSI-24	28.01-29.99	70.0	74.6	22.0	4.6	BTSE 024	24
TRxx.xxSI-26	30.00-31.99	75.0	79.6	24.0	4.6	BTSE 026	26
TRxx.xxSI-28	32.00	75.0	79.6	26.0	4.6	BTSE 028	28
TRxx.xxSI-28	32.01-33.99	74.5	79.9	26.0	5.4	BTSE 028	28
TRxx.xxSI-30	34.00-36.99	89.5	94.9	27.0	5.4	BTSE 030	30
TRxx.xxSI-33	37.00-39.00	94.5	99.9	30.0	5.4	BTSE 033	33
TRxx.xxSI-33	39.01-39.99	94.5	99.9	30.0	5.4	BTSE 033	33
TRxx.xxSI-36	40.00	99.5	104.9	33.0	5.4	BTSE 036	36

► Insert and guide pad are sold separately from drill body

TBTA-TR series



Assembly of TBTA-TR series

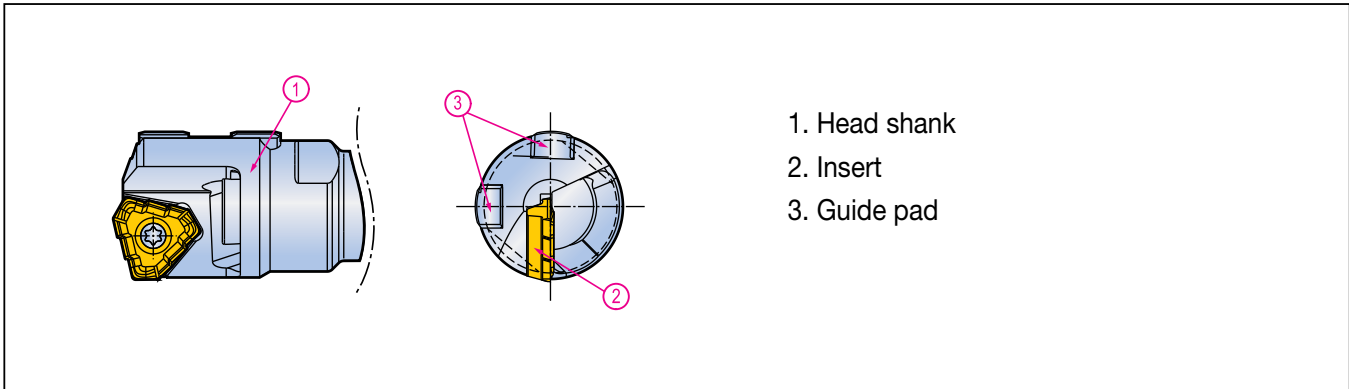

1. Head shank
2. Insert
3. Guide pad

Parts		Diameter (mm)			
		14.00~15.99 new	16.00-18.00	18.01-20.00	20.01-21.00
Insert	Insert	TOGT 070304 RS	TOGT 080305 RS	TOGT 090305 RS	TOGT 100305 RS
	Screw	SR 14-560/S	SR 14-560/S	SR 14-560/S	SR 34-506
	Wrench	T-8F	T-8F	T-8F	T-9F
Guide Pad	Guide Pad	PAD-GP05-18-060-DC-SB	PAD-GP05-18-075-DC-SB	PAD-GP06-20-085-DC-SB	PAD-GP06-20-085-DC-SB
		PAD-GP05-18-060-DC-SC	PAD-GP05-18-075-DC-SC	PAD-GP06-20-085-DC-SC	PAD-GP06-20-085-DC-SC
	Screw	SR 34-508	SR 34-508	SR 34-508	SR 34-508
	Wrench	T-7F	T-7F	T-7F	T-7F

Parts		Diameter (mm)		
		21.01-21.99	22.00-25.00	25.01-28.00
Insert	Insert	TOGT 100305 RS	TOGT 110405 RS	TOGT 120405 RS
	Screw	SR 34-506	SR14-571/S	SR 14-506
	Wrench	T-9F	T-10/5	T-15F
Guide Pad	Guide Pad	PAD-GP06-20-100-DC-SB	PAD-GP06-20-100-DC-SB	PAD-GP06-20-120-DC-SB
		PAD-GP06-20-100-DC-SC	PAD-GP06-20-100-DC-SC	PAD-GP06-20-120-DC-SC
	Screw	SR 34-508	SR 34-508	SR 34-508
	Wrench	T-7F	T-7F	T-7F

Parts		Diameter (mm)			
		28.01-29.99	30.00-32.00	32.01-39.00	39.01-40.00
Insert	Insert	TOGT 130408 RS	TOGT 130408 RS	TOGT 140510 RS	TOGT 140510 RS
	Screw	SR 16-212/L10	SR 16-212/L10	SR 16-212/L10	SR 16-212/L10
	Wrench	T-20/5	T-20/5	T-20/5	T-20/5
Guide Pad	Guide Pad	PAD-GP06-20-120-DC-SB	PAD-GP07-20-120-DC-SB	PAD-GP07-20-120-DC-SB	PAD-GP08-25-155-DC-SB
		PAD-GP06-20-120-DC-SC	PAD-GP07-20-120-DC-SC	PAD-GP07-20-120-DC-SC	PAD-GP08-25-155-DC-SC
	Screw	CSTB2.2	CSTB3S	CSTB3S	CSTB3S
	Wrench	T-7F	T-9F	T-9F	T-9F

► Insert and guide pad are sold separately from drill body