

# NPN

New Product News



## RHINO TURN

### DNGX-ST Insert for Deep Depth of Cut Machining



## KEY POINT

**TaeguTec's RHINO-TURN line now includes the DNGX-ST insert for deep depth of cut machining.**

Compatible with RHINO turning holders, the 4-corner negative DNGX-ST insert with a high rake angle designed new chip breaker provides excellent machining performance and stable tool life due to the low cutting force generated during machining. The new chip breaker enables deep depth of cut machining up to 5.0 mm so that the number of required machining paths is reduced, resulting in higher productivity.

For further details, please contact the relevant product manager.

### Features

- 4-corner double-sided insert
- 5.0 mm maximum depth of cut
  - Reduced number of machining paths for higher productivity
- Continuous chip ensures low cutting force and a precise machining dimensions
- Recommended for use with the servo oscillation function in Swiss type machines
- Higher rake angle design for low cutting force
- Compatible with RHINO turning holders

### DNGX-ST insert's hand type

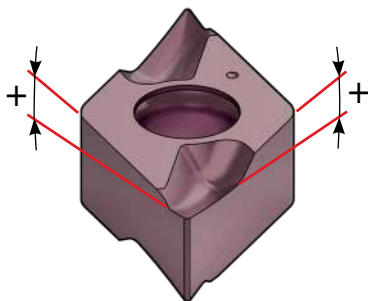

DNGX 130502M-ST-R  
Right hand insert

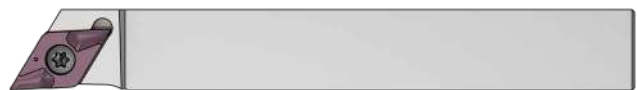

P/S/T/HDJNR...1305(-TB)  
Right hand holder



A-T/HDUNL...1305  
Left hand boring bar

### DNGX-ST cutting edge on the holder

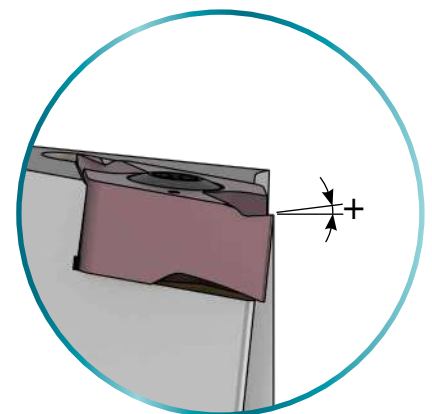
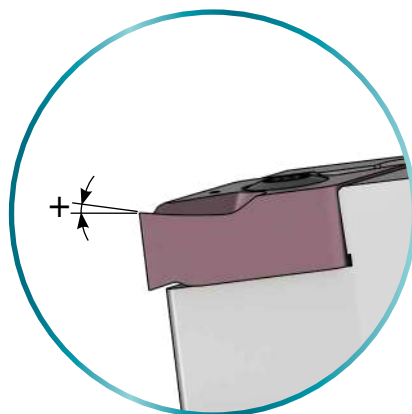
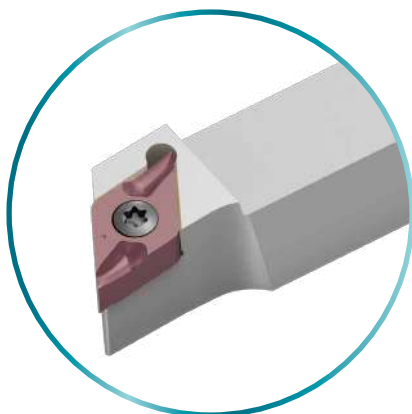

## DNGX-ST insert geometry

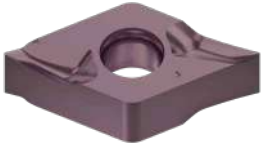
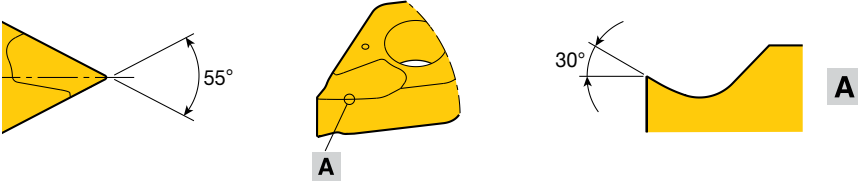
Chip breaker	Geometry
 <p data-bbox="225 651 400 685"><b>ST: for roughing</b></p>	

## Chip breaker range



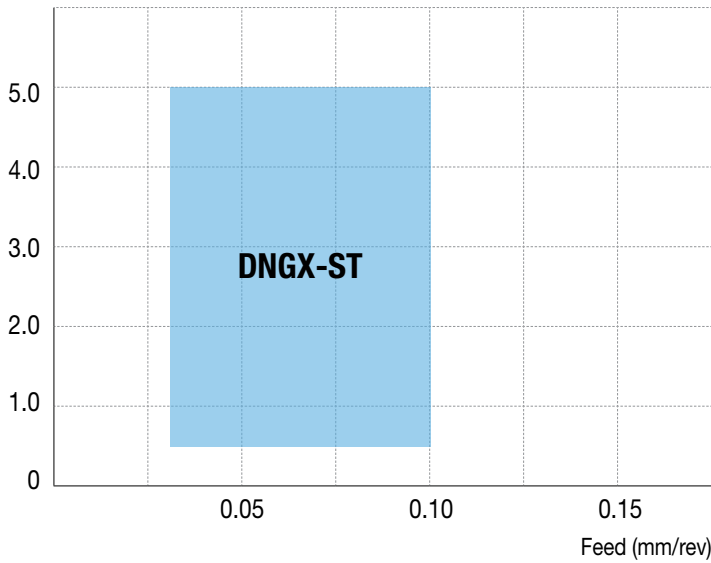













Depth of cut (mm)



- ▶ Insert: DNGX 130502M ST-R-E
- ▶ Cutting speed (V): 125 m/min
- ▶ Material: S45C (HB180-220)

## Chip curl by cutting conditions

-Excellent chip control even in deep depths of cut up to 5.0 mm

Material	Carbon Steel (AISI 1045)	Application	Ø20 external turning	RPM	2,000 rpm
ap (mm)	Feed (mm/rev)				
	0.03	0.05	0.08	0.1	
5.0					
3.0					
2.0					
1.0					

## DNGX-ST new



### Negative 55° rhombic inserts

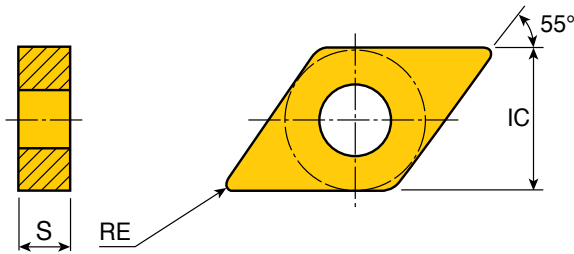

Size	Dimension (mm)		
	IC	S	RE
<b>13</b>	11.11	5.56	0.1-0.4

Insert	Designation	ap (mm)	Feed (mm/rev)	Cermet		CVD coated								PVD coated				K10							
				PV3010	CT3000	TT3005	TT7005	TT7015	TT7025	TT8105B	TT8115B	TT8125B	TT8135B	TT9215	TT9225	TT9235	TT5100		TT7100	TT5080	TT3010	TT3020	TT9020	TT4410	TT4430
Roughing For Swiss	<b>DNGX 130501M ST-R-E</b>	0.3-5.0	0.03-0.08																					●	
	<b>130502M ST-R-E</b>	0.5-5.0	0.03-0.10																						●
	<b>130504M ST-R-E</b>	0.7-5.0	0.05-0.12																						●
	<b>130501M ST-R-F</b>	0.3-5.0	0.03-0.08																				●	●	●
	<b>130502M ST-R-F</b>	0.5-5.0	0.03-0.10																				●	●	●
	<b>130504M ST-R-F</b>	0.7-5.0	0.05-0.12																				●	●	●

- ▶ M: Corner radius minus tolerance
- ▶ -R: Right hand insert
- ▶ -E: Micro honing edge
- ▶ -F: Sharp edge

●: Standard items