

NPN

New Product News



MODURDRILL

MODULAR RUSH

**New 7xD Holder for Deep Hole Drilling
with Improved Modular Head
Coolant System**

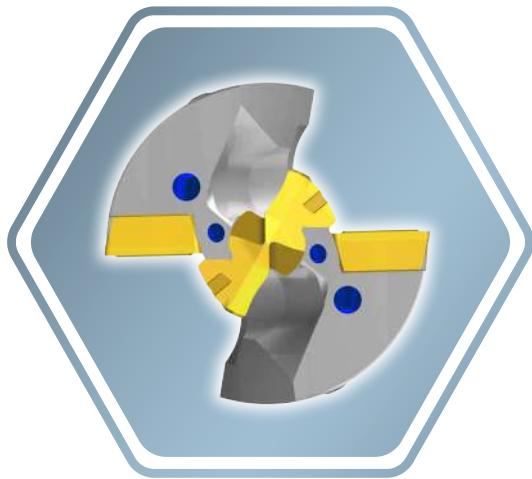

3xD

5xD

7xD

KEY POINT

The MODU-R-DRILL family now includes a 7xD holder for better stability in deep hole drilling.





TaeguTec's **MODU-R-DRILL product line has launched a new 7xD holder** that allows for deeper hole machining with excellent machinability, hole quality and tool cost savings. End-users now have the option to drill various depths, such as 3xD, 5xD and 7xD, with one head.

In addition, a coolant flow channel aimed at the cutting edge has been added to the modular head to achieve higher stability machining and improved chip evacuation.

* The MODU-R-DRILL head with the new through-coolant system will keep the current product number designation and become available after the existing stock is exhausted.

Features

- One drilling head covers various drilling depths -- 3xD, 5xD, 7xD
- 7xD drill diameter range: 26-41 mm
- Improved machining stability and tool life with through-coolant hole system

Head	Holder	
	3xD	 Drilling depth: 3xD
	5xD	 Drilling depth: 5xD
	new 7xD	 Drilling depth: 7xD

Additional coolant flow channel aimed at the cutting edge

- Improved machining stability and tool life due to smooth chip evacuation

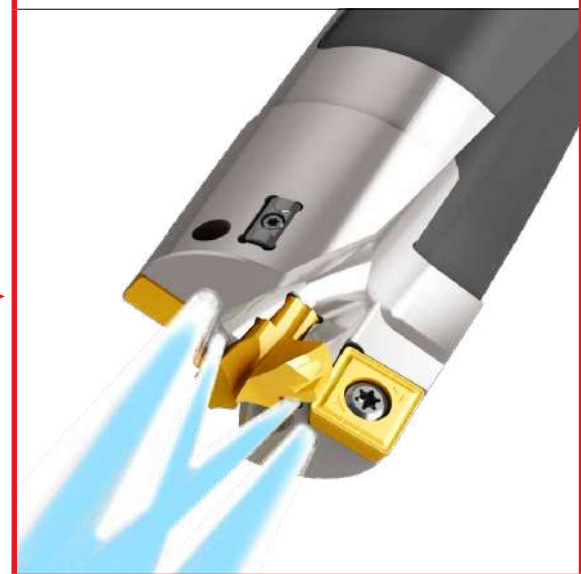
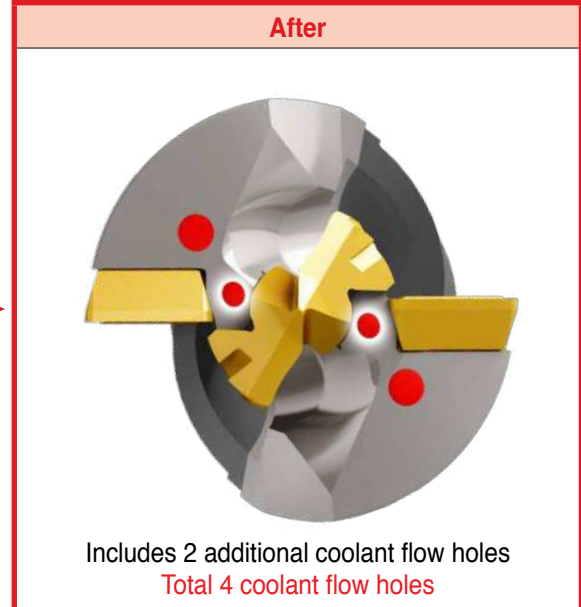
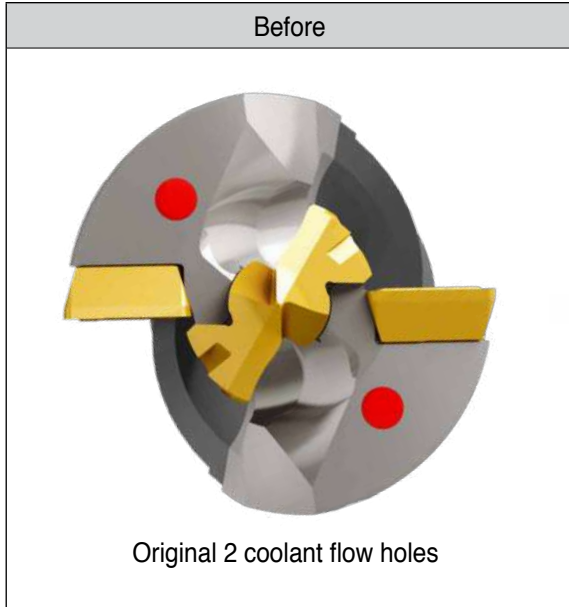

MDB...T2-7



Modular drill holders - Weldon type shank



- Drilling depth: 7xdiameter

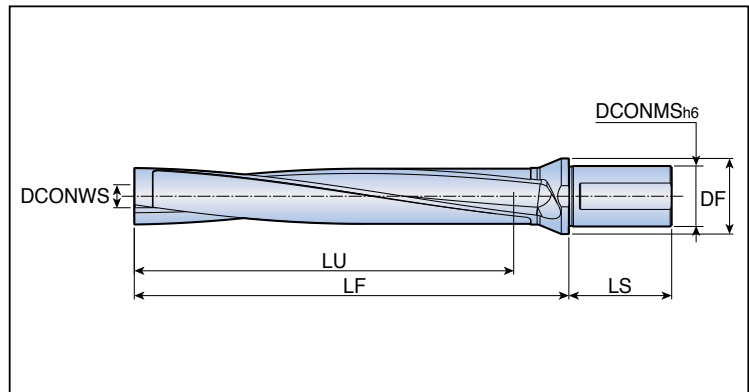

Designation	Dimension (mm)						
	DC	DCONWS	DCONMS	DF	LU	LF	LS
MDB D26/27-189-32T2-C26-7	26.0-27.0	10.4	32	40	168	202.3	60
D28/29-203-32T2-C28-7	28.0-29.0	11.2	32	40	180	216.5	60
D30/31-217-32T2-C30-7	30.0-31.0	12.0	32	40	193	229.5	60
D32/33-231-32T2-C32-7	32.0-33.0	12.8	32	40	205	243.7	60
D34/35-245-40T2-C34-7	34.0-35.0	13.6	40	50	218	260.2	68
D36/37-259-40T2-C36-7	36.0-37.0	14.4	40	50	230	274.5	68
D38/39-273-40T2-C38-7	38.0-39.0	15.2	40	50	242	287.4	68
D40/41-287-40T2-C40-7	40.0-41.0	16.0	40	50	255	301.6	68

- DC: Cutting diameter range
- DCONWS: Modular head connection size

Spare parts

Designation	Wrench	Wrench handle
MDB D26/27-7	BLD H-W2.5x280	SW6-T-SH
MDB D28/29 - D34/35-7	BLD H-W2.5x350	SW6-T-SH
MDB D36/37 - D40/41-7	BLD H-W3.0x400	SW6-T-SH

- Wrench: Disassemble the modular head from the modular body (insert from the rear shank)