

NPN

New Product News



LPHU 05-ML inserts and Holders for Small Parts on Swiss Type Machines



KEY POINT

TaeguTec introduces the LPHU 05-ML inserts and holders for small parts machining on Swiss type machines.

The miniature sector has grown due to the rise in demand for precision small parts. To strengthen its standing in the small parts machining sector, TaeguTec introduces the LPHU 05-ML inserts and holders.

The tool holders' cutting diameters range from 10 to 30 mm, and the shanks are exclusive to Swiss type machines. Additionally, the line is compatible with the current range of TANG-SPEED inserts and holders.

Please contact the product manager for more details.

Features

- LPHU 05-ML inserts specialized for small parts machining
 - Small sized 4-corners tangential insert for better tool life
 - A high rake angle for low cutting force
 - Optimized helix edge for smooth cutting
 - Variable small corner R size: 0, 0.2, 0.4 mm
- Holder size range specialized for swiss machines
 - Variable cutting diameter: Ø10, 12, 14, 16, 20, 30 mm
 - Shank size suitable for ER 16, ER 20 collets: Ø10, 12 mm
- Can replace solid end mills used in the cross tool and rear tool posts

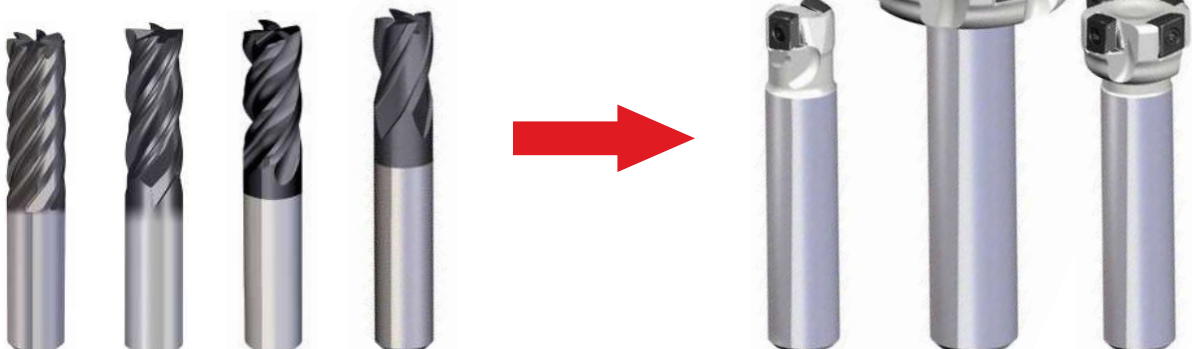
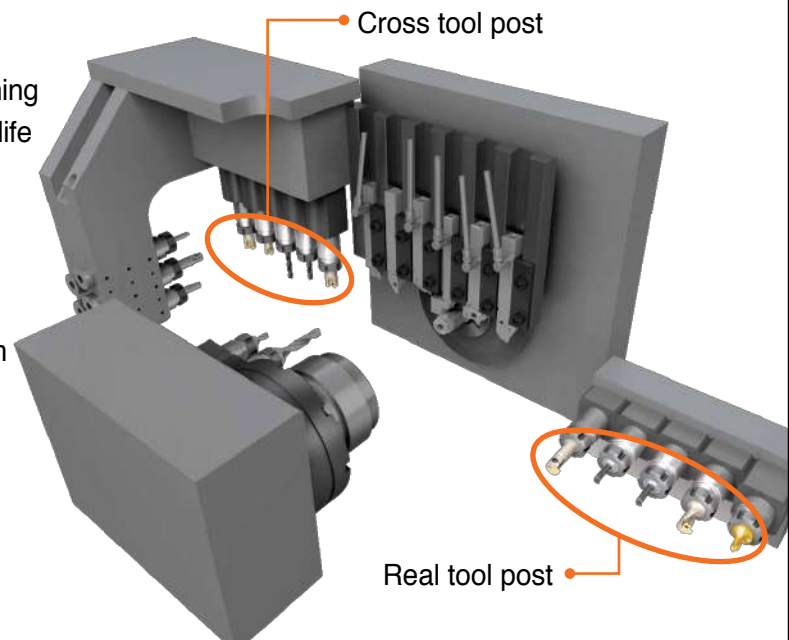

4T-MTE90-05



End mills

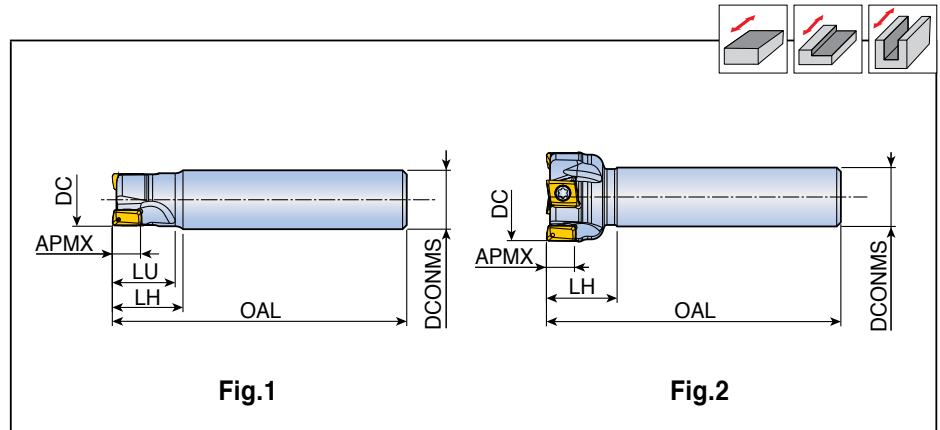

Designation		Dimension (mm)						Fig.	Insert
		DC	DCONMS	OAL	LU	LH	APMX		
4T-MTE90- 210-10-05	2	10	10	50	10	12	4.6	1	LPK(H)U 0502...
212-10-05	2	12	10	50	-	12	4.6	2	
314-10-05	3	14	10	50	-	12	4.6	2	
416-10-05	4	16	10	50	-	12	4.6	2	
420-10-05	4	20	10	50	-	12	4.6	2	
520-12-05	5	20	12	60	-	12	4.6	2	
430-10-05	4	30	10	50	-	12	4.6	2	
630-12-05	6	30	12	60	-	12	4.6	2	

Spare parts

Designation	Screw	Wrench			
4T-MTE90-05 (Ø10)	TS 18041/SG-P	TD 6P			
4T-MTE90-05 (Ø12-)	TS 18049/HG-P	TD 6P			



LPHU

Inserts

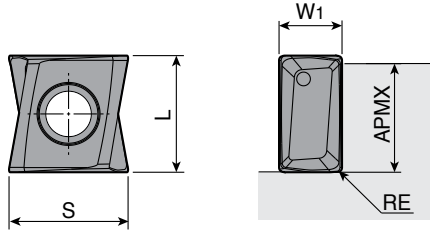

Size	Dimension (mm)				
	L	W1	S	APMX	RE
05	5	2.7	5.0	4.6	0-0.4



Insert	Designation	Recommended machining conditions		Coated
		ap (mm)	Feed (mm/tooth)	TT5525
	LPHU 050200 PNR-ML	0.1-3.5	0.08-0.03	●
	050202 PNR-ML	0.2-3.5	0.10-0.03	●
	050204 PNR-ML	0.3-3.5	0.10-0.03	●

●: Standard items