

NPN

New Product News



QUADIRUSH

INTERNAL GROOVING

Small Size Internal Grooving Inserts
with 4 Cutting Edges



KEY POINT

TaeguTec unveils the QUAD-I-RUSH small size 4 cutting edge inserts and holders for internal grooving

The **QUAD-I-RUSH** line is a highly reliable and a wide ranging internal grooving solution that uses the QUAD-RUSH's powerful three-area contact screw clamping system.

The **QUAD-I-RUSH** 4-cutting edge insert is capable of internal grooving with good chip control and excellent surface finish. The strong clamping system ensures accurate insert position repeatability when indexing insert corners, and stable performance even in high-speed and high feed conditions.

Features

- Efficient 4-cutting edge insert for internal grooving
- QUAD-RUSH's 3-area contact design with strong screw clamping
 - Long tool life with stable machining
 - Protects unused cutting edges
- Positive chip breaker provides good chip control and surface finish
- Minimum machining diameter starts from $\text{Ø}16.5$ mm
- The insert can be mounted to both left and right-handed holders; easy to manage inventory
- Internal coolant supply



Holder features

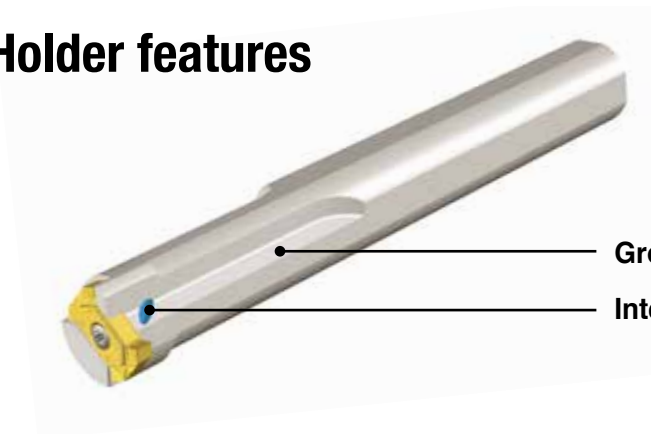

- 3-area support and screw clamping that protects unused cutting edges

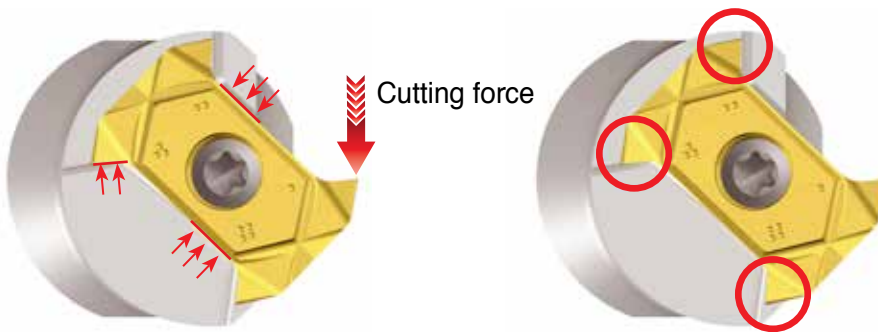

- Neutral insert type is mounted to both left and right-handed holders

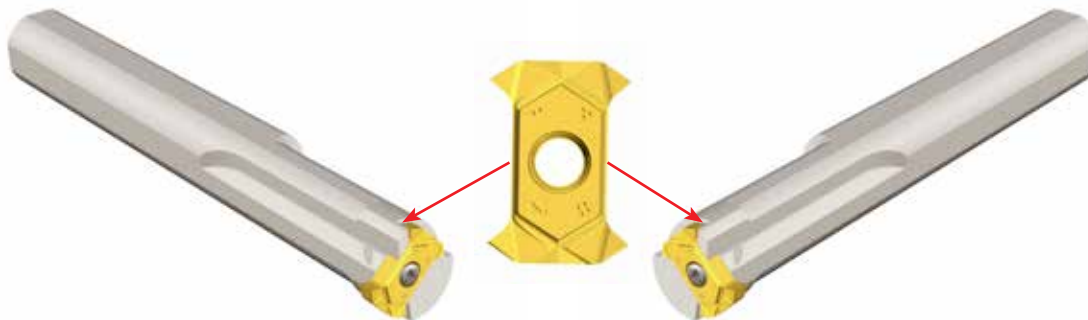

TQHIR/L



Internal grooving holders with coolant hole

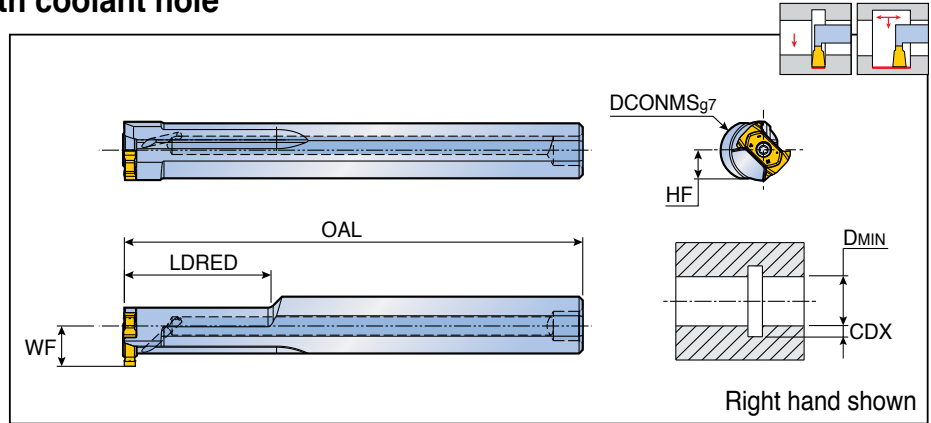

Designation	Dimension (mm)						Insert
	DCONMS	OAL	LDRED	WF	DMIN	HF	
TQHIR/L 16-16.5-14	16	125	40	11	16.5	7.5	TQIS 14
20-16.5-14	20	125	40	13	16.5	9	

• CDX: Refer to insert dimension

Spare parts

Designation	Screw	Wrench	Seal	
TQHIR/L 16	TS 25075I/HG	T 8	PL 16	
TQHIR/L 20	TS 25075I/HG	T 8	PL 20	

TQIS 14



4 cutting edge inserts for internal shallow grooving

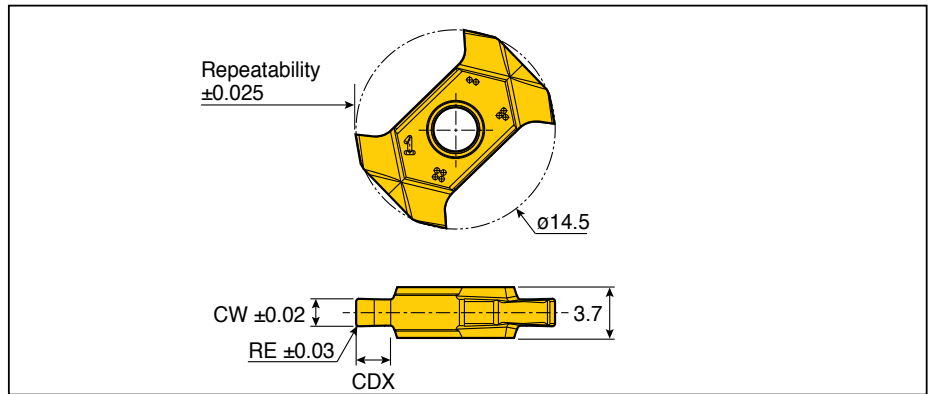

Designation	Feed (mm/rev)	Dimension (mm)			Grade
		CW	RE	CDX	
TQIS 14-1.50-0.10	0.02-0.07	1.50	0.10	2.00	●
14-2.00-0.10	0.03-0.08	2.00	0.10	2.50	●
14-2.00-0.20	0.03-0.08	2.00	0.20	2.50	●
14-2.50-0.20	0.03-0.09	2.50	0.20	2.50	●
14-3.00-0.20	0.03-0.10	3.00	0.20	2.50	●

●: Standard items

KIT COLLECTIONS

These kit products are available in the format listed below.



Cat. No.	Designation	Bill of materials	Qty.
6334871	KISFT-TQIS 14-1501-16R	TQHIR 16-16.5-14	1
		TQIS 14-1.50-0.10 TT9080	3
6334872	KISFT-TQIS 14-2002-16R	TQHIR 16-16.5-14	1
		TQIS 14-2.00-0.20 TT9080	3
6334873	KISFT-TQIS 14-3002-16R	TQHIR 16-16.5-14	1
		TQIS 14-3.00-0.20 TT9080	3
6334874	KISFT-TQIS 14-1501-20R	TQHIR 20-16.5-14	1
		TQIS 14-1.50-0.10 TT9080	3
6334875	KISFT-TQIS 14-2002-20R	TQHIR 20-16.5-14	1
		TQIS 14-2.00-0.20 TT9080	3
6334876	KISFT-TQIS 14-3002-20R	TQHIR 20-16.5-14	1
		TQIS 14-3.00-0.20 TT9080	3



Cat. No.	Designation	Bill of materials	Qty.
6337932	KISFS-TQIS 14-1501-16R	TQHIR 16-16.5-14	1
		TQIS 14-1.50-0.10 TT9080	20
6337933	KISFS-TQIS 14-2002-16R	TQHIR 16-16.5-14	1
		TQIS 14-2.00-0.20 TT9080	20
6337934	KISFS-TQIS 14-3002-16R	TQHIR 16-16.5-14	1
		TQIS 14-3.00-0.20 TT9080	20
6337935	KISFS-TQIS 14-1501-20R	TQHIR 20-16.5-14	1
		TQIS 14-1.50-0.10 TT9080	20
6337936	KISFS-TQIS 14-2002-20R	TQHIR 20-16.5-14	1
		TQIS 14-2.00-0.20 TT9080	20
6337937	KISFS-TQIS 14-3002-20R	TQHIR 20-16.5-14	1
		TQIS 14-3.00-0.20 TT9080	20



Cat. No.	Designation	Bill of materials	Qty.
6338478	KISFF-A-TQIS14-1501TT9080	TQIS 14-1.50-0.10 TT9080	50
6338479	KISFF-B-TQIS14-1501TT9080		100
6338480	KISFF-A-TQIS14-2002TT9080	TQIS 14-2.00-0.20 TT9080	50
6338481	KISFF-B-TQIS14-2002TT9080		100
6338482	KISFF-A-TQIS14-3002TT9080	TQIS 14-3.00-0.20 TT9080	50
6338483	KISFF-B-TQIS14-3002TT9080		100