

TAEGUTEC
SPEEDTEC
HIGH SPEED & FEED LINES

TAEGUTEC
SPEEDDRILL
HIGH SPEED & FEED DRILLING

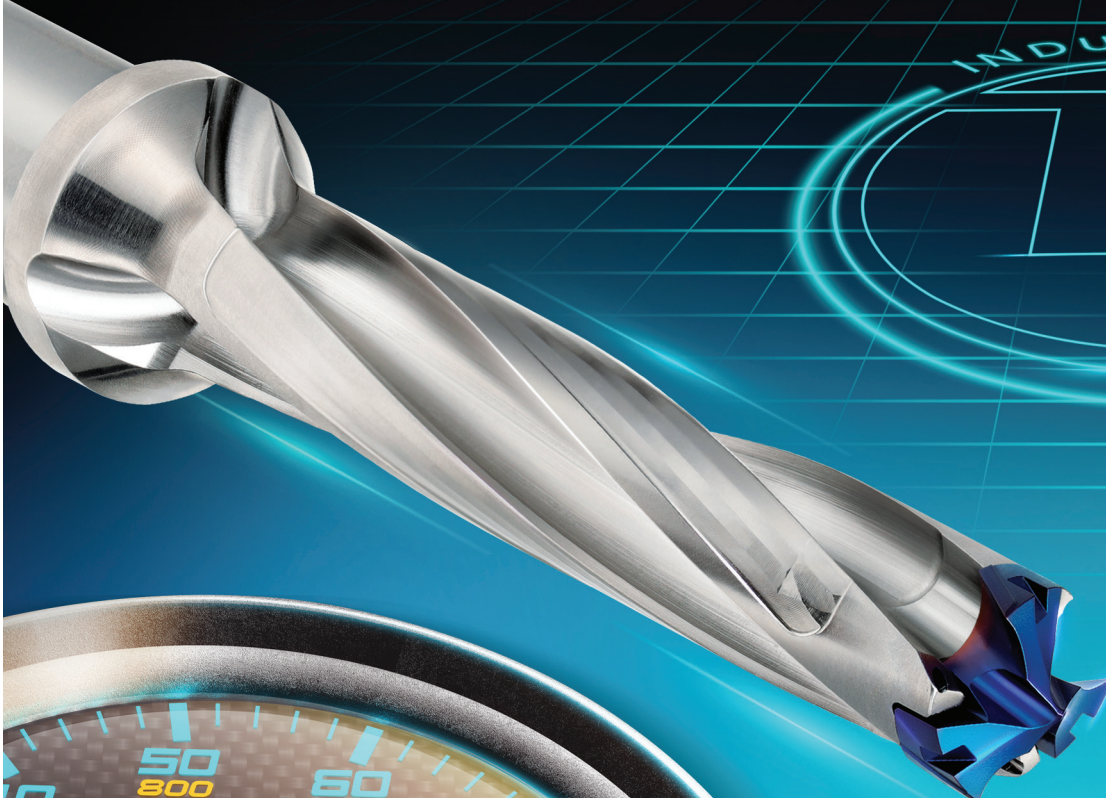

ADVANCEeMACHINING
TaeguTec Industry 4.0

INDUSTRY 4.0
 **TaeguTec**
Member IMC Group

Содержание

SOLID3DRILL
3 FLUTE

Трехперое высокопроизводительное
твердосплавное сверло

03

DRILLSPEED
INDEXABLE 3 FLUTE

Трехперое сверло со сменными
головками

06

DRILLRUSH
RUSH 2 FLUTE

Самоцентрирующаяся сверлильная
головка с интегрированным
пилотным сверлом

09

MODURDRILL
MODULAR RUSH

Уникальная модульная система для
различных диаметров и глубин
сверления

12

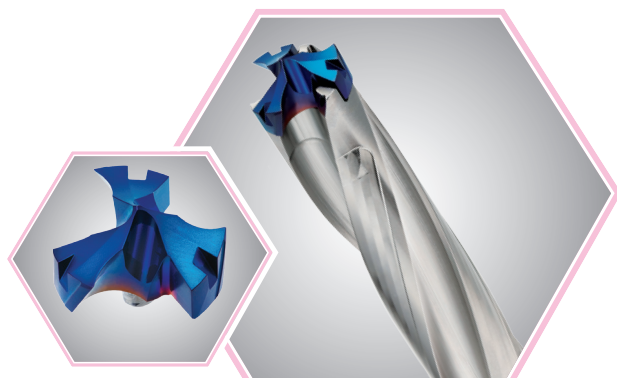

TAEGUTEC
SPEEDTEC
HIGH SPEED & FEED LINES

SOLID 3 DRILL

3 FLUTE

Трехперое
высокопроизводительное
твердосплавное сверло



INDUSTRY 4.0
TaeguTec
Member IMC Group



✓ Высокая
производительность
за счет трех зубьев



✓ Превосходная
самоцентрировка



✓ Высокая точность
отверстий



✓ Повышение стойкости
инструмента



✓ Превосходный отвод стружки

3HD...PI3



Трехперое твердосплавное сверло с подачей СОЖ через инструмент



• Глубина сверления: 3xD

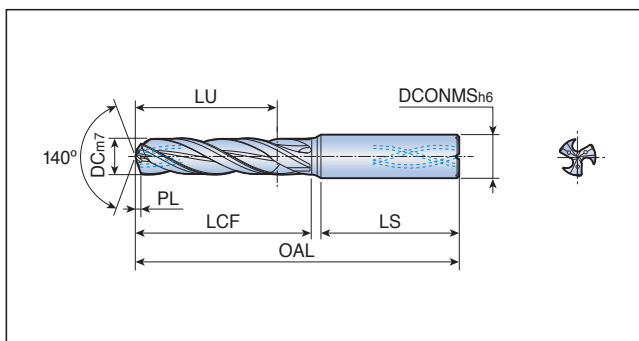

Обозначение	Размеры (мм)							Сплав
	DC	DCONMS	OAL	LU	LCF	LS	PL	TT5130
3HD 040-017-06 PI3	4.0	6.0	66	17	25	35	0.82	●
045-017-06 PI3	4.5	6.0	66	17	25	35	0.88	●
050-020-06 PI3	5.0	6.0	66	20	29	36	0.96	●
055-020-06 PI3	5.5	6.0	66	20	29	36	1.08	●
060-020-06 PI3	6.0	6.0	66	20	29	36	1.17	●
065-024-08 PI3	6.5	8.0	79	24	35	36	1.26	●
070-024-08 PI3	7.0	8.0	79	24	35	36	1.35	●
075-029-08 PI3	7.5	8.0	79	29	42	36	1.40	●
080-029-08 PI3	8.0	8.0	79	29	42	36	1.49	●
085-035-10 PI3	8.5	10.0	89	35	48	40	1.63	●
090-035-10 PI3	9.0	10.0	89	35	48	40	1.72	●
095-035-10 PI3	9.5	10.0	89	35	48	40	1.75	●
100-035-10 PI3	10.0	10.0	89	35	48	40	1.85	●
105-040-12 PI3	10.5	12.0	102	40	55	45	1.98	●
110-040-12 PI3	11.0	12.0	102	40	55	45	2.07	●
115-040-12 PI3	11.5	12.0	102	40	56	45	2.12	●
120-040-12 PI3	12.0	12.0	102	40	56	45	2.21	●

●: Стандартная позиция

3HD...PI5



Трехперое твердосплавное сверло с подачей СОЖ через инструмент



• Глубина сверления: 5xD

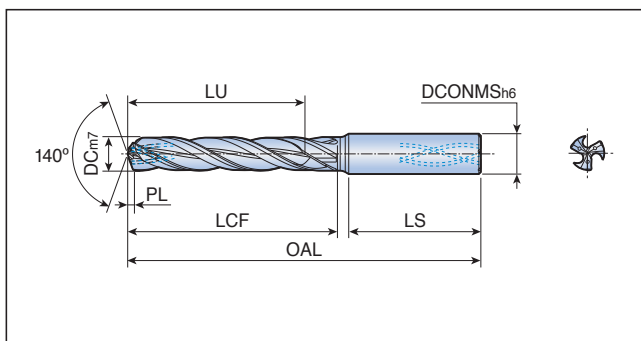

Обозначение	Размеры (мм)							Сплав
	DC	DCONMS	OAL	LU	LCF	LS	PL	TT5130
3HD 040-029-06 PI5	4.0	6.0	74	29	37	35	0.82	●
045-029-06 PI5	4.5	6.0	74	29	37	35	0.88	●
050-035-06 PI5	5.0	6.0	82	35	45	36	0.96	●
055-035-06 PI5	5.5	6.0	82	35	45	36	1.08	●
060-035-06 PI5	6.0	6.0	82	35	45	36	1.17	●
065-043-08 PI5	6.5	8.0	91	43	54	36	1.26	●
070-043-08 PI5	7.0	8.0	91	43	54	36	1.35	●
075-043-08 PI5	7.5	8.0	91	43	54	36	1.40	●
080-043-08 PI5	8.0	8.0	91	43	54	36	1.49	●
085-049-10 PI5	8.5	10.0	103	49	62	40	1.63	●
090-049-10 PI5	9.0	10.0	103	49	62	40	1.72	●
095-049-10 PI5	9.5	10.0	103	49	62	40	1.75	●
100-049-10 PI5	10.0	10.0	103	49	62	40	1.85	●
105-056-12 PI5	10.5	12.0	118	56	71	45	1.98	●
110-056-12 PI5	11.0	12.0	118	56	71	45	2.07	●
115-056-12 PI5	11.5	12.0	118	56	72	45	2.12	●
120-056-12 PI5	12.0	12.0	118	56	72	45	2.21	●

●: Стандартная позиция

TAEGUTEC
SPEEDTEC
HIGH SPEED & FEED LINES

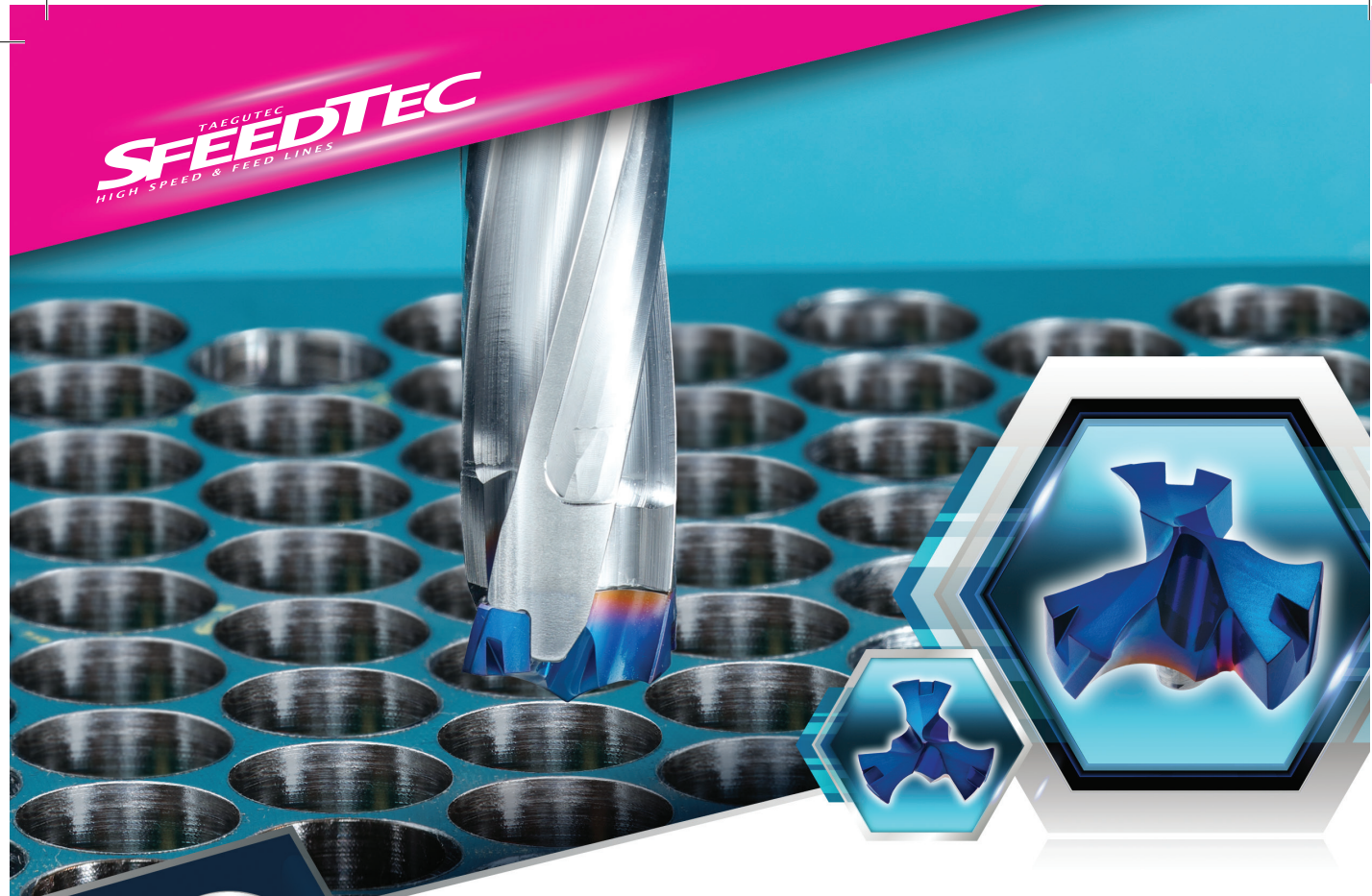

DRILLSPEED

INDEXABLE 3 FLUTE

Трехперое сверло со сменными головками



✓ Уникальная самоцентрирующаяся геометрия



✓ Повышение производительности за счет трех режущих кромок



✓ Высокая точность отверстия



✓ Не требуется время для наладки, удобная система крепления



✓ Новое блестящее покрытие голубого цвета



TaeguTec
Member IMC Group

3ED...T...-3D

DRILLSPEED
INDEXABLE 3 FLUTE

Корпус сверла с хвостовиком Weldon



- Глубина сверления: 3xD

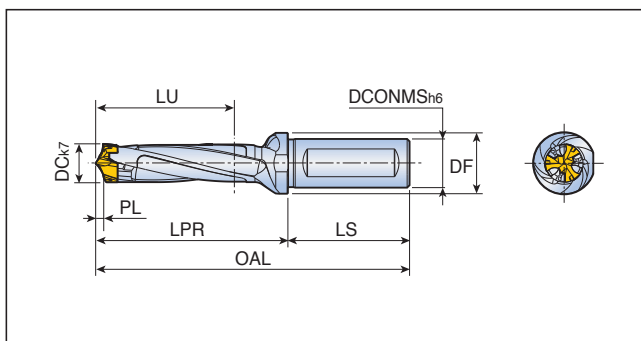

Обозначение	Размеры (мм)								Зажимной ключ
	DC	DCONMS	DF	LU	LPR	LS	PL	SSC	
3ED 160-169-20T3-3D	16.0-16.9	20	25	52	79.0	50	3.70	16	K 3ED D16-D17
170-179-20T3-3D	17.0-17.9	20	25	55	84.0	50	3.90	17	K 3ED D16-D17
180-189-25T2-3D	18.0-18.9	25	32	58	90.1	56	4.08	18	K 3ED D18-D19
190-199-25T2-3D	19.0-19.9	25	32	61	94.7	56	4.27	19	K 3ED D18-D19
200-209-25T2-3D	20.0-20.9	25	32	64	99.3	56	4.45	20	K 3ED D20-D21

3ED...T...-5D

DRILLSPEED
INDEXABLE 3 FLUTE

Корпус сверла с хвостовиком Weldon

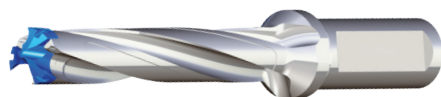

- Глубина сверления: 5xD

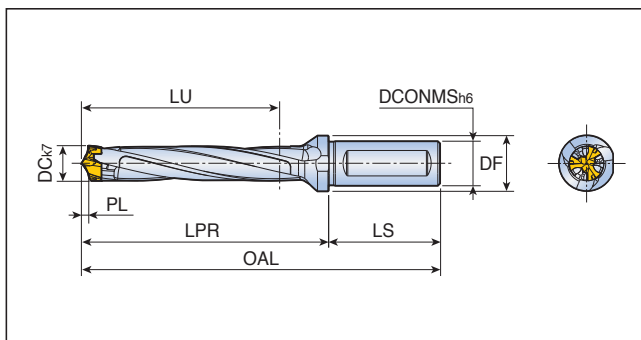

Обозначение	Размеры (мм)								Зажимной ключ
	DC	DCONMS	DF	LU	LPR	LS	PL	SSC	
3ED 160-169-20T3-5D	16.0-16.9	20	25	84	111.0	50	3.70	16	K 3ED D16-D17
170-179-20T3-5D	17.0-17.9	20	25	89	118.0	50	3.90	17	K 3ED D16-D17
180-189-25T2-5D	18.0-18.9	25	32	94	126.1	56	4.08	18	K 3ED D18-D19
190-199-25T2-5D	19.0-19.9	25	32	99	132.7	56	4.27	19	K 3ED D18-D19
200-209-25T2-5D	20.0-20.9	25	32	104	139.3	56	4.45	20	K 3ED D20-D21

- OAL= LPR+LS
- SSC : Код размера

3ED...-P+

DRILLSPEED
INDEXABLE 3 FLUTE

Техкрюмчюная сверлильная головка

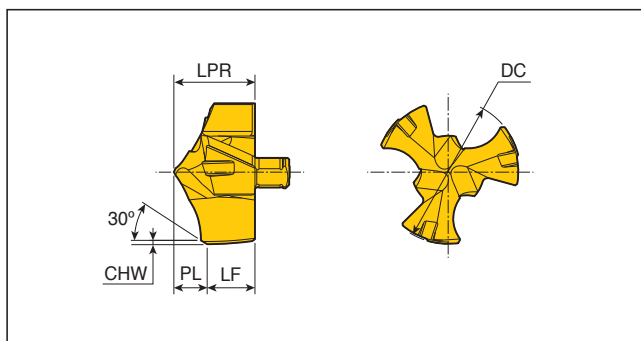

Обозначение	Размеры (мм)						Сплав
	DC	LPR	PL	LF	CHW	SSC	ТТ5130
3ED- 160-P+	16.0	9.00	3.70	5.30	0.40	16	●
165-P+	16.5	9.00	3.71	5.29	0.40	16	●
170-P+	17.0	9.50	3.90	5.62	0.40	17	●
175-P+	17.5	9.50	3.91	5.61	0.40	17	●
180-P+	18.0	10.10	4.08	6.03	0.40	18	●
185-P+	18.5	10.10	4.09	6.02	0.40	18	●
190-P+	19.0	10.70	4.27	6.44	0.40	19	●
195-P+	19.5	10.70	4.28	6.43	0.40	19	●
200-P+	20.0	11.30	4.45	6.86	0.40	20	●
205-P+	20.5	11.30	4.46	6.85	0.40	20	●

● SSC : Код размера

●: Стандартная позиция

TAEGUTEC
SPEEDTEC
HIGH SPEED & FEED LINES



DRILLRUSH

RUSH 2 FLUTE

Самоцентрирующаяся
сверлильная головка
с революционной геометрией



✓ Превосходная
самоцентрировка



✓ Высокая точность
отверстий



✓ Высокая производительность не
требуется пилотное отверстие



✓ Усиленная режущая кромка



TaeguTec
Member IMC Group

TCD-P+



Самоцентрирующаяся сверлильная головка

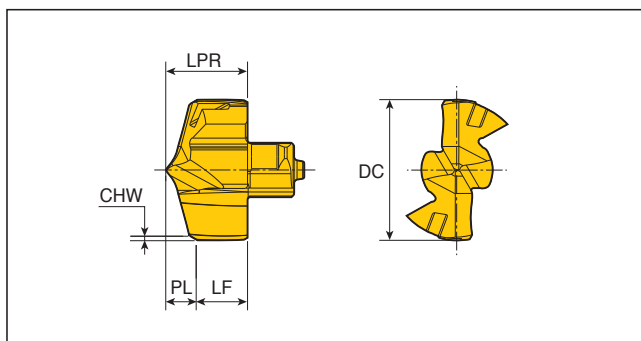

Обозначение	Размеры (мм)						Сплав
	DC	LPR	PL	LF	CHW	SSC	TT9080
TCD-060-P+	6.0	4.00	1.46	2.54	0.27	6	●
065-P+	6.5	4.30	1.55	2.75	0.27	6.5	●
068-P+	6.8	4.30	1.55	2.75	0.27	6.5	●
070-P+	7.0	4.60	1.64	2.96	0.27	7	●
075-P+	7.5	4.60	1.64	2.96	0.27	7	●
080-P+	8.0	5.40	1.81	3.59	0.27	8	●
085-P+	8.5	5.40	1.81	3.59	0.27	8	●
086-P+	8.6	5.40	1.81	3.59	0.27	8	●
090-P+	9.0	5.80	1.98	3.82	0.27	9	●
095-P+	9.5	5.80	1.98	3.82	0.27	9	●
099-P+	9.9	5.80	1.98	3.82	0.27	9	●
100-P+	10.0	6.20	2.33	3.87	0.38	10	●
102-P+	10.2	6.20	2.33	3.87	0.38	10	●
103-P+	10.3	6.20	2.33	3.87	0.38	10	●
105-P+	10.5	6.20	2.33	3.87	0.38	10	●
107-P+	10.7	6.20	2.33	3.87	0.38	10	●
108-P+	10.8	6.20	2.33	3.87	0.38	10	●
110-P+	11.0	6.60	2.50	4.10	0.38	11	●
111-P+	11.1	6.60	2.50	4.10	0.38	11	●
115-P+	11.5	6.60	2.50	4.10	0.38	11	●
120-P+	12.0	7.00	2.67	4.33	0.38	12	●
123-P+	12.3	7.00	2.67	4.33	0.38	12	●
125-P+	12.5	7.00	2.67	4.33	0.38	12	●
126-P+	12.6	7.00	2.67	4.33	0.38	12	●
127-P+	12.7	7.00	2.67	4.33	0.38	12	●
130-P+	13.0	7.60	2.85	4.75	0.38	13	●
135-P+	13.5	7.60	2.85	4.75	0.38	13	●
140-P+	14.0	8.15	3.02	5.13	0.38	14	●
141-P+	14.1	8.15	3.02	5.13	0.38	14	●
142-P+	14.2	8.15	3.02	5.13	0.38	14	●
143-P+	14.3	8.15	3.02	5.13	0.38	14	●
145-P+	14.5	8.15	3.02	5.13	0.38	14	●
146-P+	14.6	8.15	3.02	5.13	0.38	14	●
150-P+	15.0	8.73	3.19	5.54	0.38	15	●

● SSC : Код размера

● Стандартная позиция

TCD-P+



Самоцентрирующаяся сверлильная головка

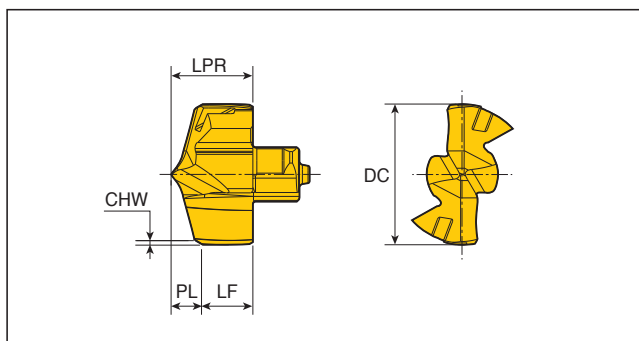

Обозначение	Размеры (мм)						Сплав
	DC	LPR	PL	LF	CHW	SSC	TT9080
TCD- 151-P+	15.1	8.73	3.19	5.54	0.38	15	●
152-P+	15.2	8.73	3.19	5.54	0.38	15	●
155-P+	15.5	8.73	3.19	5.54	0.38	15	●
159-P+	15.9	8.73	3.19	5.54	0.38	15	●
160-P+	16.0	9.30	3.46	5.84	0.44	16	●
161-P+	16.1	9.30	3.46	5.84	0.44	16	●
163-P+	16.3	9.30	3.46	5.84	0.44	16	●
164-P+	16.4	9.30	3.46	5.84	0.44	16	●
165-P+	16.5	9.30	3.46	5.84	0.44	16	●
167-P+	16.7	9.30	3.46	5.84	0.44	16	●
170-P+	17.0	9.90	3.63	6.27	0.44	17	●
173-P+	17.3	9.90	3.63	6.27	0.44	17	●
175-P+	17.5	9.90	3.63	6.27	0.44	17	●
180-P+	18.0	10.50	3.81	6.69	0.44	18	●
185-P+	18.5	10.50	3.81	6.69	0.44	18	●
190-P+	19.0	11.00	3.98	7.02	0.44	19	●
192-P+	19.2	11.00	3.98	7.02	0.44	19	●
193-P+	19.3	11.00	3.98	7.02	0.44	19	●
194-P+	19.4	11.00	3.98	7.02	0.44	19	●
195-P+	19.5	11.00	3.98	7.02	0.44	19	●
200-P+	20.0	11.60	4.15	7.45	0.44	20	●
205-P+	20.5	11.60	4.15	7.45	0.44	20	●
206-P+	20.6	11.60	4.15	7.45	0.44	20	●
210-P+	21.0	12.18	4.32	7.86	0.44	21	●
215-P+	21.5	12.18	4.32	7.86	0.44	21	●
220-P+	22.0	12.76	4.50	8.26	0.44	22	●
222-P+	22.2	12.76	4.50	8.26	0.44	22	●
225-P+	22.5	12.76	4.50	8.26	0.44	22	●
230-P+	23.0	13.33	4.67	8.66	0.44	23	●
235-P+	23.5	13.33	4.67	8.66	0.44	23	●
240-P+	24.0	13.90	4.84	9.06	0.44	24	●
245-P+	24.5	13.90	4.84	9.06	0.44	24	●
250-P+	25.0	14.50	5.01	9.49	0.44	25	●
255-P+	25.5	14.50	5.01	9.49	0.44	25	●
259-P+	25.9	14.50	5.01	9.49	0.44	25	●

● SSC : Код размера

● Стандартная позиция

TAEGUTEC
SPEEDTEC
HIGH SPEED & FEED LINES



MODURDRILL

MODULAR RUSH

Уникальная систем для
различных диаметров и
глубин сверления



✓ Экономичное решение



✓ Повышение производительности за счет новой геометрии



✓ Хорошее качество получаемых отверстий



✓ Удобное крепление сменных модулей



✓ Эффективное удаление стружки



TaeguTec
Member IMC Group

TNDH-TP

Модульная сверлильная головка

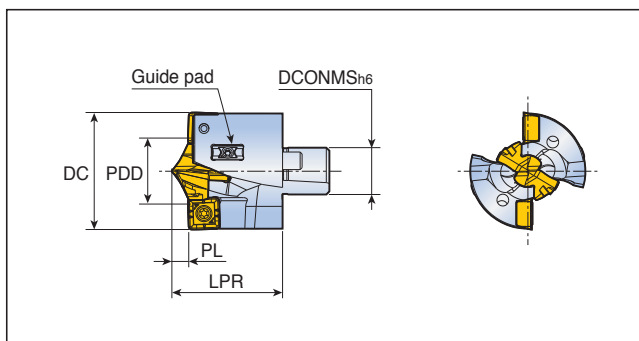

Обозначение	Размеры (мм)					Зажимной ключ	Пластина	
	DC	DCONMS	LPR	PL	PDD		Центральная	Внешняя
TNDH 2600-C26-TP	26	10.4	24.94	3.98	15.9	K TCD D15-CO	TCD-159-P-CO+	SPGX 06...DW
2700-C26-TP	27	10.4	25.35	4.14	16.9	K TCD D16-CO	TCD-169-P-CO+	SPGX 06...DW
2800-C28-TP	28	11.2	26.86	4.29	17.9	K TCD D17-CO	TCD-179-P-CO+	SPGX 06...DW
2900-C28-TP	29	11.2	26.58	3.97	15.9	K TCD D15-CO	TCD-159-P-CO+	SPGX 07...DW
3000-C30-TP	30	12.0	28.34	4.14	16.9	K TCD D16-CO	TCD-169-P-CO+	SPGX 07...DW
3100-C30-TP	31	12.0	28.51	4.30	17.9	K TCD D17-CO	TCD-179-P-CO+	SPGX 07...DW
3200-C32-TP	32	12.8	30.27	4.46	18.9	K TCD D18-CO	TCD-189-P-CO+	SPGX 07...DW
3300-C32-TP	33	12.8	29.84	3.97	15.9	K TCD D15-CO	TCD-159-P-CO+	SPGX 09...DW
3400-C34-TP	34	13.6	31.60	4.14	16.9	K TCD D16-CO	TCD-169-P-CO+	SPGX 09...DW
3500-C34-TP	35	13.6	31.76	4.30	17.9	K TCD D17-CO	TCD-179-P-CO+	SPGX 09...DW
3600-C36-TP	36	14.4	33.52	4.46	18.9	K TCD D18-CO	TCD-189-P-CO+	SPGX 09...DW
3700-C36-TP	37	14.4	33.26	4.14	16.9	K TCD D16-CO	TCD-169-P-CO+	SPGX 11...DW
3800-C38-TP	38	15.2	35.01	4.30	17.9	K TCD D17-CO	TCD-179-P-CO+	SPGX 11...DW
3900-C38-TP	39	15.2	35.18	4.46	18.9	K TCD D18-CO	TCD-189-P-CO+	SPGX 11...DW
4000-C40-TP	40	16.0	36.94	4.62	19.9	K TCD D19-CO	TCD-199-P-CO+	SPGX 11...DW
4100-C40-TP	41	16.0	37.10	4.78	20.9	K TCD D20-CO	TCD-209-P-CO+	SPGX 11...DW
4200-C42-TP	42	16.8	38.87	4.95	21.9	K TCD D21-CO	TCD-219-P-CO+	SPGX 11...DW
4300-C42-TP	43	16.8	38.93	5.11	22.9	K TCD D22-CO	TCD-229-P-CO+	SPGX 11...DW
4400-C44-TP	44	17.6	40.80	5.28	23.9	K TCD D23-CO	TCD-239-P-CO+	SPGX 11...DW
4500-C44-TP	45	17.6	40.96	5.44	24.9	K TCD D24-CO	TCD-249-P-CO+	SPGX 11...DW
4600-C46-TP	46	18.4	42.16	4.95	21.9	K TCD D21-CO	TCD-219-P-CO+	SPGX 14...DW
4700-C46-TP	47	18.4	42.32	5.11	22.9	K TCD D22-CO	TCD-229-P-CO+	SPGX 14...DW
4800-C48-TP	48	19.2	43.95	5.28	23.9	K TCD D23-CO	TCD-239-P-CO+	SPGX 14...DW
4900-C48-TP	49	19.2	44.26	5.44	24.9	K TCD D24-CO	TCD-249-P-CO+	SPGX 14...DW
5000-C48-TP	50	19.2	46.02	5.61	25.9	K TCD D25-CO	TCD-259-P-CO+	SPGX 14...DW

• DCONMS: Присоединительный размер корпуса

Комплектующие

Обозначение	Для двухшагового винта		Для SPGX		Для направляющей	
	Винт1	Ключ1	Винт2	Ключ2	Винт3	Ключ3
TNDH 2600-2800	TDPS 0512-W2.0	F-W2.0	TS 22052I/HG	TD 7	TS 20043I/HG-P	TD 6P
TNDH 2900-3200	TDPS 0512-W2.0	F-W2.0	TS 25064I	TD 8	TS 20043I/HG-P	TD 6P
TNDH 3300-3500	TDPS 0512-W2.0	F-W2.0	TS 35088I	TD 10	TS 20043I/HG-P	TD 6P
TNDH 3600	TDPS 0618-W2.5	F-W2.5	TS 35088I	TD 10	TS 20043I/HG-P	TD 6P
TNDH 3700-4300	TDPS 0618-W2.5	F-W2.5	TS 40093I	TD 15	TS 20043I/HG-P	TD 6P
TNDH 4400-4500	TDPS 0722-W3.0	F-W3.0	TS 40093I	TD 15	TS 20043I/HG-P	TD 6P
TNDH 4600-5000	TDPS 0722-W3.0	F-W3.0	SO 50090I	TD 20	TS 20043I/HG-P	TD 6P

MDB...T2-3/5

MODURDRILL
MODULAR RUSH

Корпус модульного сверла с хвостовиком Weldon

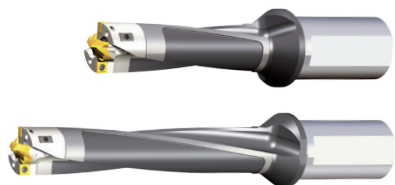

- Глубина сверления: 3, 5xD

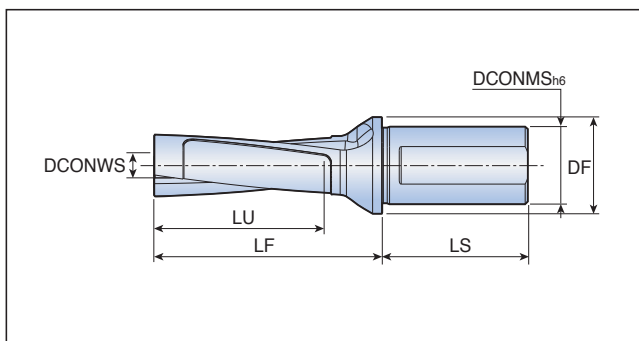

3xD

Обозначение	Размеры (мм)						
	DC	DCONWS	DCONMS	DF	LU	LF	LS
MDB D26/27-081-32T2-C26-3	26-27	10.4	32	40	60	94.3	60
D28/29-087-32T2-C28-3	28-29	11.2	32	40	64	100.5	60
D30/31-093-32T2-C30-3	30-31	12.0	32	40	69	105.5	60
D32/33-099-32T2-C32-3	32-33	12.8	32	40	73	111.7	60
D34/35-105-40T2-C34-3	34-35	13.6	40	50	78	120.2	68
D36/37-111-40T2-C36-3	36-37	14.4	40	50	82	126.5	68
D38/39-117-40T2-C38-3	38-39	15.2	40	50	86	131.4	68
D40/41-123-40T2-C40-3	40-41	16.0	40	50	91	137.6	68
D42/43-129-40T2-C42-3	42-43	16.8	40	50	95	143.8	68
D44/45-135-40T2-C44-3	44-45	17.6	40	50	99	150.0	68
D46/47-141-50T2-C46-3	46-47	18.4	50	60	104	154.5	80
D48/50-150-50T2-C48-3	48-50	19.2	50	60	111	160.9	80

5xD

Обозначение	Размеры (мм)						
	DC	DCONWS	DCONMS	DF	LU	LF	LS
MDB D26/27-135-32T2-C26-5	26-27	10.4	32	40	114	148.3	60
D28/29-145-32T2-C28-5	28-29	11.2	32	40	122	158.5	60
D30/31-155-32T2-C30-5	30-31	12.0	32	40	131	167.5	60
D32/33-165-32T2-C32-5	32-33	12.8	32	40	139	177.7	60
D34/35-175-40T2-C34-5	34-35	13.6	40	50	148	190.2	68
D36/37-185-40T2-C36-5	36-37	14.4	40	50	156	200.5	68
D38/39-195-40T2-C38-5	38-39	15.2	40	50	164	209.4	68
D40/41-205-40T2-C40-5	40-41	16.0	40	50	173	219.6	68
D42/43-215-40T2-C42-5	42-43	16.8	40	50	181	229.8	68
D44/45-225-40T2-C44-5	44-45	17.6	40	50	189	240.0	68
D46/47-235-50T2-C46-5	46-47	18.4	50	60	198	248.5	80
D48/50-250-50T2-C48-5	48-50	19.2	50	60	211	258.9	80

- DC: Диапазон диаметров устанавливаемых головок
- DCONWS: Присоединительный размер модульной головки

Комплектующие

Обозначение	Ключ		Рукоятка ключа
	3xD	5xD	
MDB D26/27-D34/35	BLD H-W2.5x210	BLD H-W2.5x280	SW6-T-SH
MDB D36/37-D42/43	BLD H-W3.0x225	BLD H-W3.0x310	
MDB D44/45-D48/50	BLD H-W4.0x255	BLD H-W4.0x350	

- Откройте модульную головку от корпуса инструмента с помощью ключа

TCD...P-CO+

MODURDRILL
MODULAR RUSH

Самоцентрирующаяся сверлильная головка

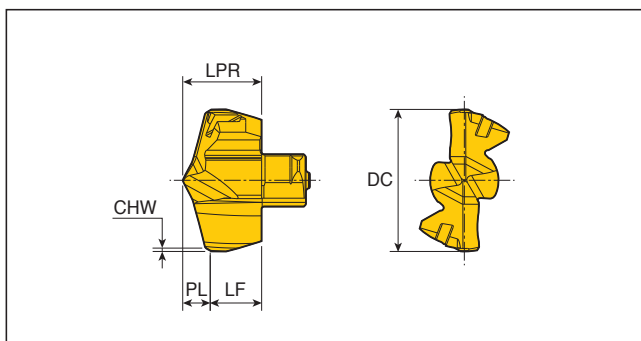

Обозначение	Размеры (мм)						Сплав
	DC	LPR	PL	LF	CHW	SSC	ТТ9080
TCD- 159-P-CO+	15.9	8.73	3.17	5.56	0.38	15	●
169-P-CO+	16.9	9.30	3.34	5.96	0.38	16	●
179-P-CO+	17.9	9.90	3.50	6.40	0.38	17	●
189-P-CO+	18.9	10.50	3.66	6.84	0.38	18	●
199-P-CO+	19.9	11.00	3.82	7.18	0.38	19	●
209-P-CO+	20.9	11.60	3.98	7.62	0.38	20	●
219-P-CO+	21.9	12.18	4.15	8.03	0.38	21	●
229-P-CO+	22.9	12.76	4.31	8.45	0.38	22	●
239-P-CO+	23.9	13.33	4.48	8.85	0.38	23	●
249-P-CO+	24.9	13.90	4.64	9.26	0.38	24	●
259-P-CO+	25.9	14.50	4.81	9.69	0.38	25	●

● SSC: Код размера

●: Стандартная позиция

SPGX...DW

MODURDRILL
MODULAR RUSH

Пластина

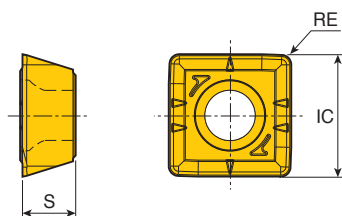

Размер	Размеры (мм)			
	IC	S	RE	
06	6.07	2.38	0.4	
07	8.02	3.97	0.8	
09	9.91	4.30	0.8	
11	11.62	4.80	0.8	
14	14.41	5.20	1.2	

Пластина	Обозначение	Покрытие						Без покрытия
		ТТ9080	ТТ8020	ТТ9300	ТТ9030	ТТ6030	ТТ7400	К10
	SPGX 060204 DW	●						
	07T308 DW	●						
	090408 DW	●						
	110408 DW	●						
	140512 DW	●						

●: Стандартная позиция

TAEGUTEC **SPEEDTEC** HIGH SPEED & FEED LINES

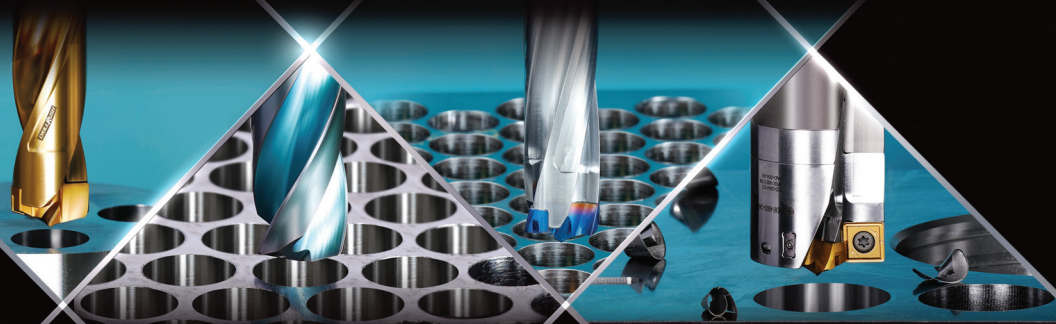

TaeguTec
Member IMC Group



- Cat.No: 6338716
- Russian Version: CT 09/2019
- ©TaeguTec LTD.

Штабквартира в Корее

1040 Gachang-ro, Gachang-myeon, Dalseong-gun, Daegu, 42936, Korea

Tel: +82-53-760-7640 Web: www.taegutec.com